



## KL FRESNEL 8 CW™

**KL FRESNEL 8 CW™** is a 350W 5,600K Cool White LED fresnel on par with compatible tungsten halogen models. Features include manual and DMX control, 11° to 57° wide motorized zoom, manual and DMX controlled dimmer, shutter, and zoom, dimmer and zoom rotary dials, smooth 16-bit selectable dimming modes and curves, LED refresh rate frequency adjustment for flicker free operation for TV and FILM, removable barn doors (included), RDM (remote device management) protocol support, 3/5pin DMX and powerCON TRUE1 in/out connections, 4 button control panel, LCD menu display, multiple unit power linking, a universal auto switching power supply (100-240v), gel frame and rotating bar doors (included), and a 3 clamp position adjustable mounting yoke.

### FEATURES

- 350W 5,600K Cool White LED Engine**
- Output On Par with Tungsten Halogen Models**
- 11° to 57° Wide Motorized Zoom**
- Manual and DMX Controlled Dimmer, Shutter, and Zoom**
- Dimmer and Zoom Rotary Dials**
- Smooth 16-bit Selectable Dimming Modes and Curves**
- LED Refresh Rate Adjustment**
- Flicker Free Operation for TV and FILM**
- RDM (Remote Device Management)**
- Gel Frame and Rotating Barn Doors (included)**
- 3 Clamp Position Adjustable Mounting Yoke**



**SPECIFICATIONS**

**SOURCE**

350W 5,600K Cool White LED  
 50,000 Hour Average LED Life\*

\*May vary depending on several factors including but not limited to:  
 Environmental Conditions, Power/Voltage, Usage Patterns (On-Off Cycling), Control and Dimming.

**PHOTOMETRIC DATA**

(pending)

**EFFECTS**

11° - 57° Wide Motorized Zoom  
 Electronic Dimmer and Strobe  
 Variable 16-bit Dimming Modes and Curves

**COLOR**

Cool White 5,600K

**CONTROL / CONNECTIONS**

Manual and DMX Controlled Dimmer, Shutter, and Zoom  
 Dimmer and Zoom Rotary Dials  
 (5) DMX Channel Modes (2 / 3 / 3 / 6 / 7)  
 4 Button Control Panel LCD Menu Display  
 RDM (Remote Device Management)  
 3/5pin DMX and powerCON TRUE1 In/Out

**SIZE / WEIGHT**

Length: 23.95" (608.4mm)  
 Width: 12.89" (327.5mm)  
 Vertical Height: 17.95" (456mm)  
 Weight: 28.0 lbs. (12.7kg)

**ELECTRICAL / THERMAL**

AC 100-240V - 50/60Hz  
 430W Max Power Consumption  
 Multiple Unit Power Linking  
 5°F to 113°F (-15°C to 45°C)

**INCLUDED ITEMS**

Gel Frame and Rotating Barn Doors  
 powerCON TRUE1 Power Cable  
 Barn Doors and Fixture Safety Cables

**APPROVALS / RATINGS**



**PHOTOMETRIC DATA (pending)**

**DIMENSIONAL DIAGRAMS**

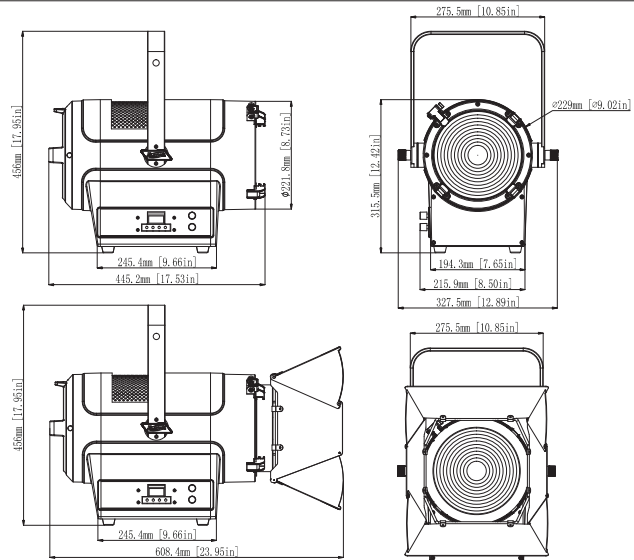

**ORDERING INFORMATION**

<b>1236100169</b>	KL FRESNEL 8 CW
<b>1741000032</b>	DT Trigger Clamp
<b>1621000071</b>	PC 1m Powercon True1 Link Cable (Additional cable lengths available)



Specifications subject to change without notice ©Elation Professional 03/17/19

Elation Professional USA | 6122 S. Eastern Ave. | Los Angeles, CA. 90040  
 323-582-3322 | 323-832-9142 fax | www.elationlighting.com | info@elationlighting.com

Elation Professional B.V. | Junostraat 2 | 6468 EW Kerkrade, The Netherlands  
 +31 45 546 85 66 | +31 45 546 85 96 fax | www.elationlighting.eu | info@elationlighting.eu